

# PRODUCT DATA SHEET

CLA INOX230A • 807723



BRAND



## PRODUCT DETAILS

The Claytech Self-Priming Inox Series multistage pump is well-known for its quiet and reliability in the Australian market. Designed for use in a larger home, it is more energy efficient than a jet pump and can self prime to a depth of 4 meters. This makes it ideal for above and below ground rainwater tanks.

## BENEFITS

- Self priming enables the pump to draw reliably from water lower than the pump inlet
- High flow, flat consistent performance curve.
- Complies with AS/NZS 4020 requirements

## FEATURES

- Multi-stage pump
- Quiet, reliable operation
- Designed for larger homes
- Self-Priming
- Automatic Operation - adjustable start pressure
- Controller includes a pressure gauge
- Inbuilt dry run protection

## TECHNICAL DATA

P1 RATED POWER (W)	550W
MAX. FLOW [LPM]	100 lpm
MAX. HEAD [M]	35m
WORKING TEMPERATURE	< 40°C
LIQUID TEMPERATURE	2°C - 35°C
MAX. WORKING PRESSURE	6 Bar
MOTOR DUTY	S1 Continuous
MOTOR PROTECTION LEVEL	Class F
PUMP BODY	Technopolymer
DIFFUSER MATERIAL	Technopolymer
MOTOR PROTECTION	In-built auto re-setting thermal overload
CAPACITOR	12.5 uF +/-5% 450V

RATED VOLTAGE	220V-240V 50 Hz
RATED CURRENT	3.9A @ 230V
POWER CABLE TYPE	2m H07RN-F
PROTECTION CLASS	IPX4
INLET	1" BSPF
OUTLET	1" BSPF
MECHANICAL SEAL	Carbon/Ceramic
MOTOR SHAFT	Stainless Steel
IMPELLER MATERIAL	Stainless Steel
AUTOMATION FUNCTION	Yes, with adjustable start pressure
NET WEIGHT (KG)	Pump only 11.0kg
PACKAGE DIMENSION	570Lx270Wx350H (mm)

## HYDRAULIC PERFORMANCE

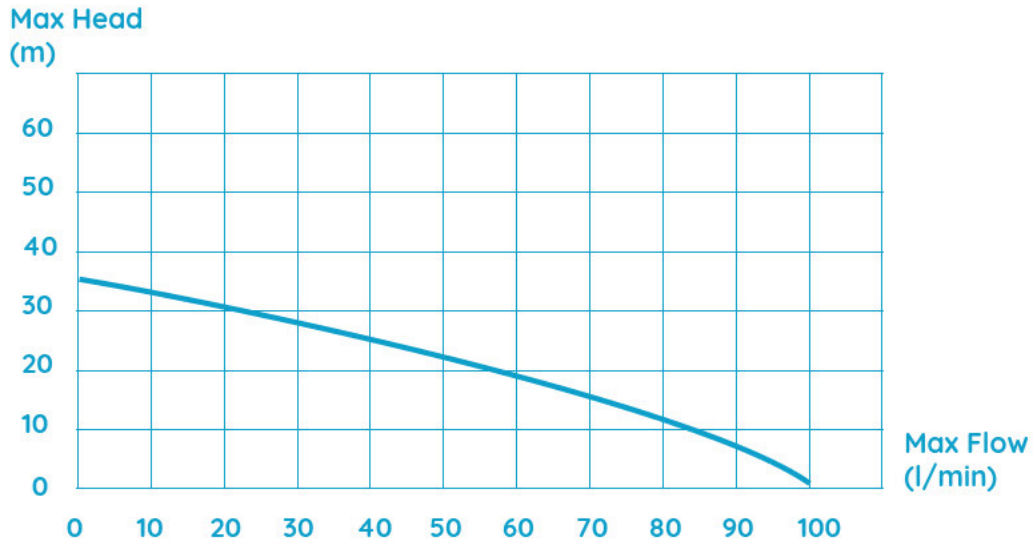

## DIMENSIONS

### INLET / OUTLET

1" BSPF

### DIMENSIONS

Pump Only: 380 mm long, 220 High, 215mm wide

With controller: 450mm high

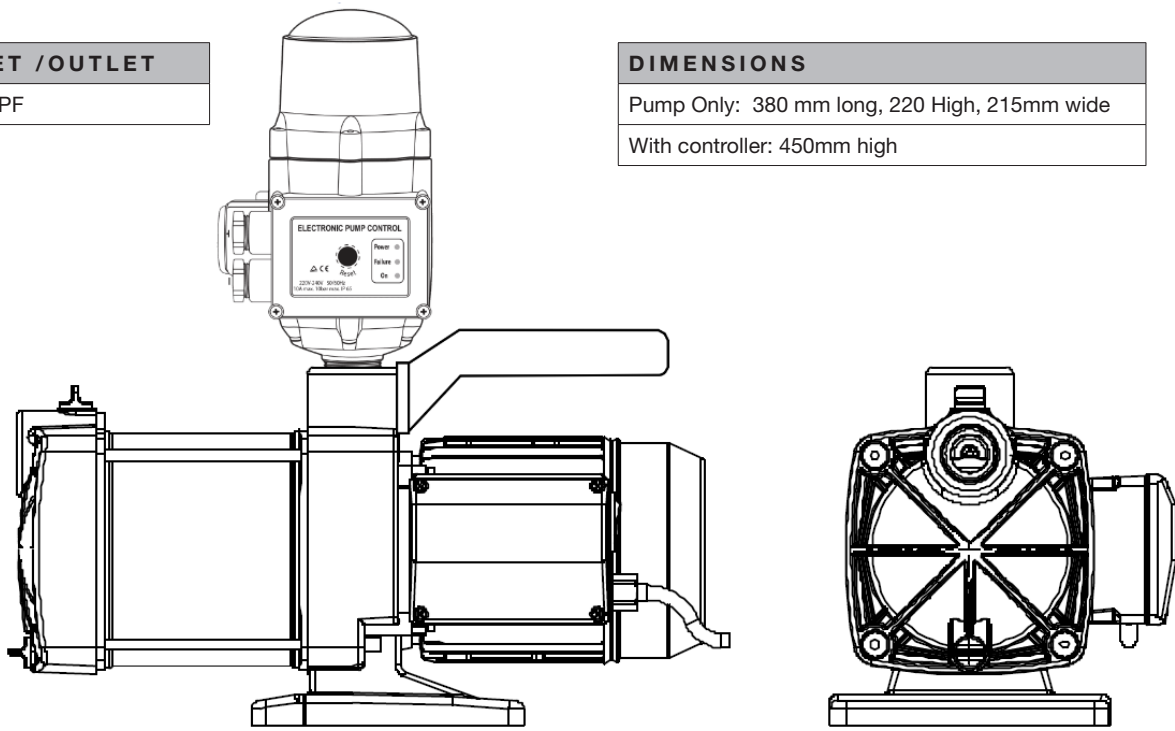

### BASE FOOT

170 mm long, 275mm wide

## WARRANTY / CERTIFICATIONS

